

Typical configuration of a dosing system

- A Conveying unit
- B Digital dosing unit
- C Control

Component B is described below.

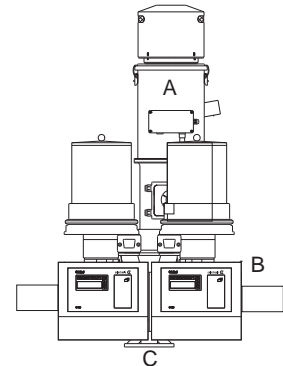

Brief Description

The Colorblend M Duo is a synchronized, digital dosing system designed to precisely dose plastic additives (either in pellet or powder form) on any plastics processing machine, whether injection molding, blow molding, or all extrusion applications. The precise dosing of additives is accomplished using a correctly sized dosing disc in combination with a special DC drive motor and our easy to operate control. This combination allows for additives to be dosed in synch with the processing machine and the flow of the main component material. When the additives and main material hit the processing screw, they will be mixed at exactly the right proportion, according to your inputted recipe. The Colorblend M Duo controllers are connected to the process machine and monitor the screw recovery time for injection, injection blowmolding and the screw speed of an extruder.

Colortronic guarantees delivery of a homogeneous mix every time without risk of de-mixing even with the use of micro-batch (or micro pellets).

Our design makes material changeover almost effortless. Simply lift two quick disconnects and lift off the additive station. By the use of a spare station, changeover is immediate. If you elect not to purchase a spare station, clean up and material change occurs off the machine in minutes, reducing downtime and risk of injury. Additive may also be automatically loaded by the use of one of Colortronic's hopper loaders.

The Colorblend M Duo is mounted directly in the throat of the processing machine. We have various sizes and adapters to accommodate machine sizes and hopper loader configurations.

- Colortronic dosing systems meet European "CE" requirements.



Technical Information

Basic Version

- Components to dose granulate, micro-batch/pellets or powder (please specify requirement)
- Quick disconnect for changeover/cleaning
- Sampling tube for simple calibration
- Ability to handle materials up to 80 °C (176 °F)
- Separate easy to operate control with 40" connection wire
- Connection wire to processing machine
- Operating voltage 230 +/-10 %, AC, Single phase, 50/60Hz
- 0.4 kW operating load
- Weight 45 kg/100 lbs

Optional Equipment

- Spare station for immediate changeover for pellets or powders
- Option for abrasive materials
- Audible alarm
- Alarm light
- Low level sensors
- Intermediate hoppers for main component side
- Hopper loaders for automatic refill
- Special voltage
- Larger base piece for larger processing machines

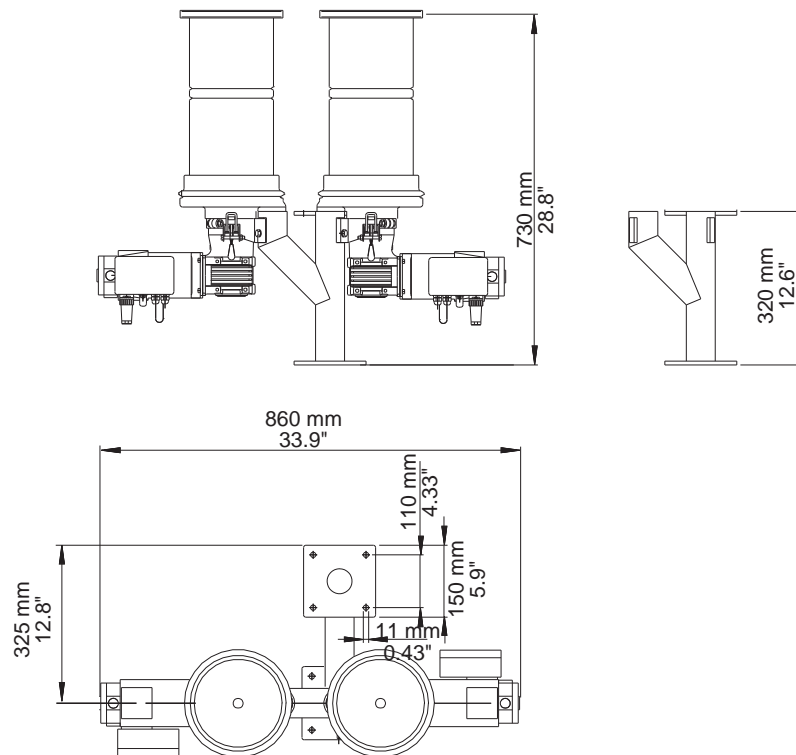

www.colortronic.com

Colortronic GmbH
Germany

☎ +49 61 75 7 92-0
☎ +49 61 75 7 92-1 79
✉ info@colortronic.de

Colortronic Inc.
USA

☎ +1 856 312 96 00
☎ +1 856 312 96 96
✉ ctusa@colortronic.com

Colortronic Systems Pte. Ltd
Singapore

☎ +65 77 77 665
☎ +65 77 88 671
✉ ctasia@colortronic.com

Colortronic U.K. Ltd.
Great Britain

☎ +44 12 46 260 222
☎ +44 12 46 455 420
✉ sales@colortronic.co.uk

Colortronic s.a.r.l.
France

☎ +33 03 88 59 18 10
☎ +33 03 88 59 18 11
✉ ctfrance@colortronic.com

Colortronic AG
Switzerland

☎ +41 62 889 25 25
☎ +41 62 889 25 26
✉ info@colortronic.ch