

Typical application of a crystallizer.

- A Crystallizer
- B Drier
- C Conveying system
- D Drying hopper
- E Feeding system

Component a is described below.

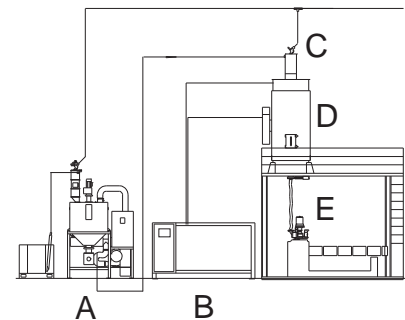

Brief Description

Application

Colortronic crystallizers also convert other amorphous plastics into semi-crystalline ones so that a subsequent drying sequence is possible without problems.

- Colortronic crystallizers are designed for continuous, 24 hour operation.
- Colortronic crystallizers meet all CE requirements

Sturdy Construction

In the process, the material is heated and kept moving constantly during the crystallization phase by an agitator. This prevents the clumping of the material during the crystallization phase.

The system is operated by a micro-processor SPC control system.



Technical Information

Basic Version

- All parts coming into contact with the products are made of stainless steel
- Large cleaning opening
- Micro-processor control system
- Special starting program
- Pre-selectable crystallization time
- Automatic inlet valve
- Filling level indicator
- Safety temperature limiter on heater
- Even, optimum degree of crystallization due to horizontal agitator
- Continuous material process

Performance

- Maximum throughput (0.85 kg/l)
 CPK 50: 80 kg/hr
 CPK 200: 300 kg/hr
 CPK 400: 600 kg/hr
 CPK 600: 800 kg/hr
- Voltage 400 V +/- 10%, 3 AC, 50 Hz
- Power consumption
 CPK 50: 4 kW
 CPK 200: 19 kW
 CPK 400: 34 kW
 CPK 600: 40 kW

Optional Equipement

- De-dusting separator for processing of dusty materials
- V24 printer interface

	A	B	C
CPK 50	1290	1900	800
CPK 200	1600	2400	1280
CPK 400	1850	2780	1490
CPK 600	1850	3180	1490

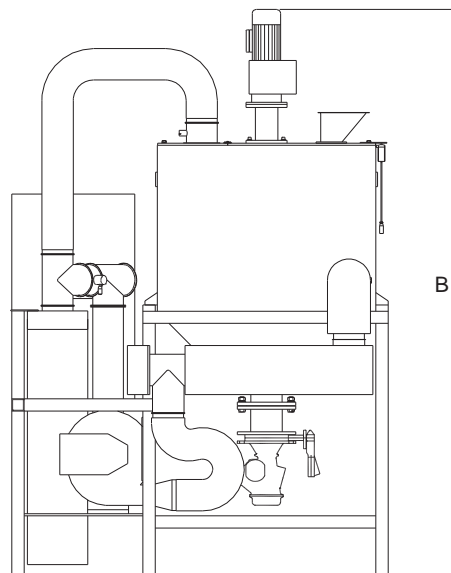
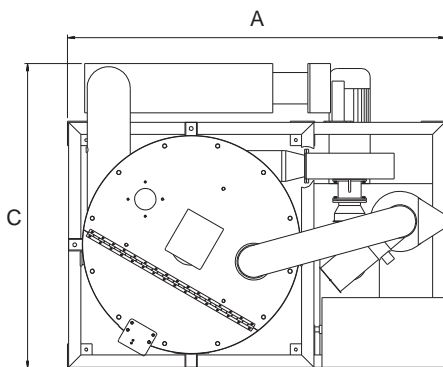

www.colortronic.com

Colortronic GmbH
 Germany

☎ +49 61 75 7 92-0
 📠 +49 61 75 7 92-1 79
 ✉ info@colortronic.de

Colortronic Inc.
 USA

☎ +1 856 312 96 00
 📠 +1 856 312 96 96
 ✉ ctusa@colortronic.com

Colortronic Systems Pte. Ltd
 Singapore

☎ +65 77 77 665
 📠 +65 77 88 671
 ✉ ctasia@colortronic.com

Colortronic U.K. Ltd.
 Great Britain

☎ +44 12 46 260 222
 📠 +44 12 46 455 420
 ✉ sales@colortronic.co.uk

Colortronic s.a.r.l.
 France

☎ +33 03 88 59 18 10
 📠 +33 03 88 59 18 11
 ✉ ctfrance@colortronic.com

Colortronic AG
 Switzerland

☎ +41 62 889 25 25
 📠 +41 62 889 25 26
 ✉ info@colortronic.ch