

Typical set-up for a single conveying unit.

- A Single Conveying Unit
- B Dosing System
- C Processing Machine
- D Suction Pipe

Component A is described below.

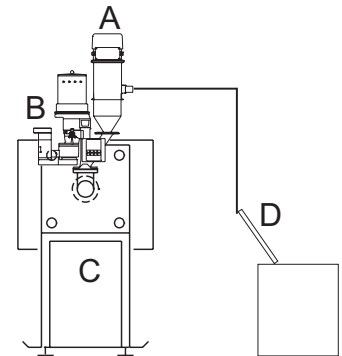

Brief Description

Application

Colortronic single conveying units are designed for use in facilities in which require independent machine conveying systems.

The CSE single conveying units have been developed for conveying thermoplastic granules.

A typical area of application is for processing machines and drying hoppers with throughputs of up to 200 kg/hr (440 lbs/hr).

- Colortronic single conveying units are designed for continuous 24-hour operation.
- Colortronic single conveying units meet the European "CE" requirements.

Rugged, modular construction

The CSE excels due to its compact design making it possible to mount the unit onto smaller machines and drying hoppers.

A highly efficient vacuum pump guarantees that large throughputs of material can be conveyed regardless of space constraints.



Technical Information

Basic Version

- Integrated control, mounted at the rotating turbine head
- Integrated vacuum turbine
- Two-component valve output
- Cleaning and maintenance flap
- Parts coming in contact with material are made of stainless steel
- Easy to remove turbine head for quick cleaning
- Material clearing valve output

Optional Equipment

- Integrated textile filter with pneumatic cleaning
- Granulator level sensor input
- Automatic shut down with lack of material, incl. alarm output

Performance

- Typical throughput:
up to 200 kg/h
- Hopper loader capacity:
appr. 2,5 l
- Connected load:
115 V, AC, 60 Hz, 0,8 kW
230 V, AC, N, PE, 50 Hz, 0,8 kW

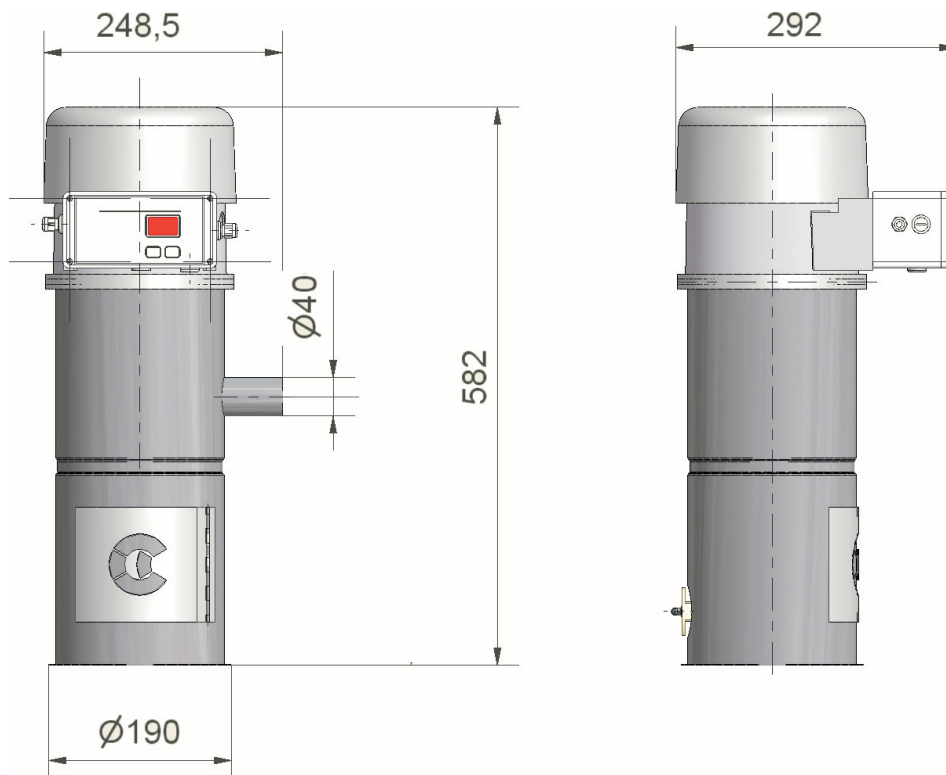

www.colortronic.com

Colortronic AG Switzerland

☎ +41 62 889 25 25
✉ +41 62 889 25 26
✉ info@colortronic.ch

Colortronic GmbH Germany

☎ +49 61 75 7 92-0
✉ +49 61 75 7 92-1 79
✉ info@colortronic.de

Colortronic Sarl France

☎ +33 03 88 59 18 10
✉ +33 03 88 59 18 11
✉ info@colortronic.fr

Colortronic srl Italy

☎ +39 0 131 87 29 33
✉ +39 0 131 87 29 41
✉ info@colortronic.it

Colortronic Systems Pte. Ltd Singapore

☎ +65 677 77 665
✉ +65 677 88 671
✉ ctasia@colortronic.com

Colortronic N.A. Inc. USA

☎ +1 856 312 96 00
✉ +1 856 312 96 96
✉ ctusa@colortronic.com

Colortronic U.K. Ltd. Great Britain

☎ +44 12 46 260 222
✉ +44 12 46 455 420
✉ sales@colortronic.co.uk