

Typical set up for a multiple vacuum conveying system.

- A Material clearing valve
- B Rotary valve system.
- C Two component valve
- D Hopper loader
- E Conveying control system
- F Safety filter
- G Vacuum pump
- H Granulator
- I Processing machine

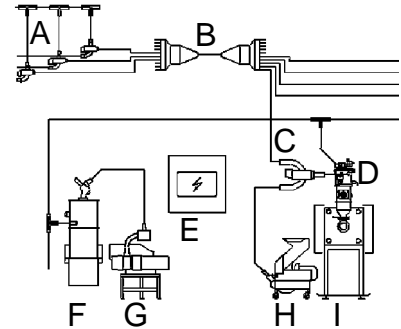

Component D is described below.

Brief Description

Application

The Colortronic CSK 5-H allows for the conveying of free flowing pelletized plastic materials using vacuum receivers which integrates into a central conveying system. The loader is specially designed for processing highly abrasive materials.

- Colortronic hopper loaders are designed for continuous 24-hour operation
- Colortronic hopper loaders meet the European "CE" requirements.

Rugged, modular construction

The hopper loaders work without filters and are made of stainless steel and toughened glass, guaranteeing minimum abrasion and corrosion.

The operating conditions are indicated on the hopper loader by large LED's as follows:
on; demand; conveying; alarm.

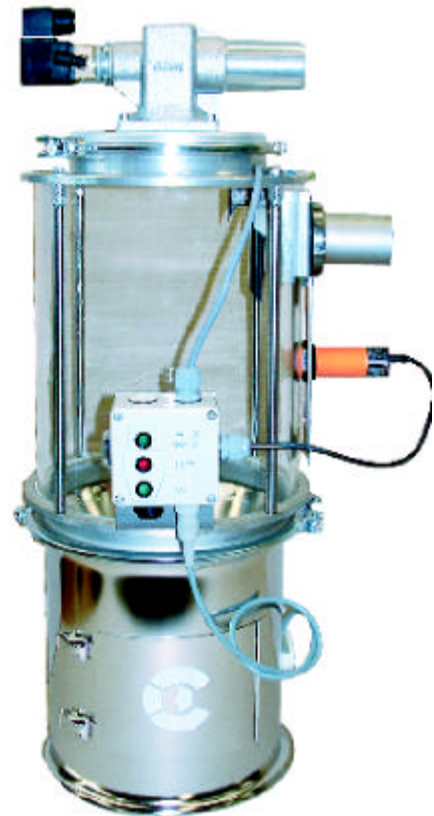

Technical Information

Basic Version

- Hopper loader capacity approx. 5 l
- Made of stainless steel DIN material No. 1.4301 and toughened glass
- Cleaning opening
- Hinged lid
- Pneumatic valve
- On/off switch on the hopper loader
- Indication of operating conditions at the hopper loader: on, demand, conveying, alarm
- ZKW output
- Voltage 24 VDC
- Maximum material temperature approx: 160 °C / 320 °F

Optional Equipment

- Diaphragm valve
- Adjustable maximum level probe
- Connection modules

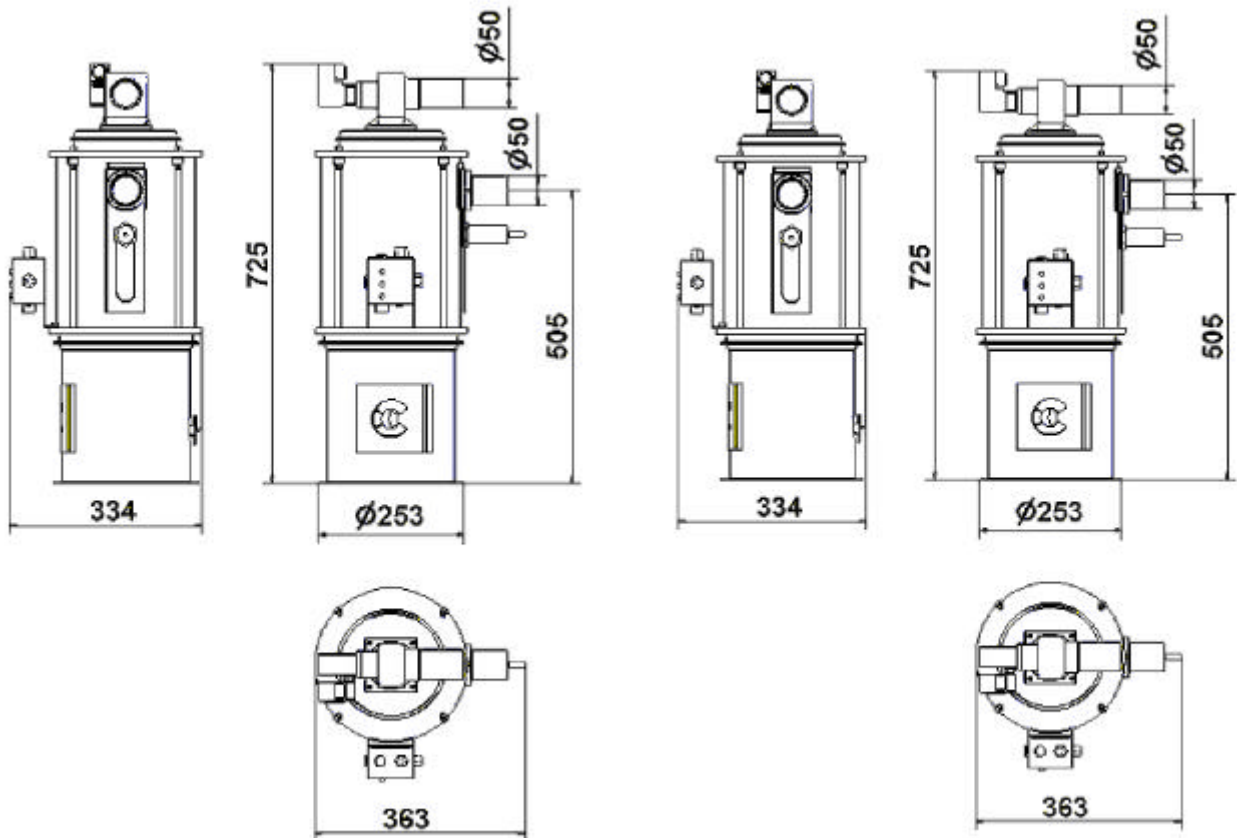

www.colortronic.com

Colortronic GmbH
Germany

☎ +49 61 75 7 92-0
☎ +49 61 75 7 92-1 79
✉ info@colortronic.de

Colortronic AG
Switzerland

☎ +41 62 889 25 25
☎ +41 62 889 25 26
✉ info@colortronic.ch

Colortronic NA Inc.
USA

☎ +1 856 312 96 00
☎ +1 856 312 96 96
✉ ctusa@colortronic.com

Colortronic Systems Pte. Ltd
Singapore

☎ +65 677 77 665
☎ +65 677 88 671
✉ ctasia@colortronic.com

Colortronic Sarl
France

☎ +33 03 88 59 18 10
☎ +33 03 88 59 18 11
✉ info@colortronic.fr

Colortronic Srl
Italy

☎ +39 0 131 87 29 33
☎ +39 0 131 87 29 41
✉ info@colortronic.it

Colortronic U.K. Ltd.
Great Britain

☎ +44 12 46 260 222
☎ +44 12 46 455 420
✉ sales@colortronic.co.uk