

Typical set-up of a dosing system with a twin screw control feeder.

- A Dosing station
- B Motor
- C Smart Force transducer
- D Weighing Unit Component
- E Gravimetric dosing control

D is described below.

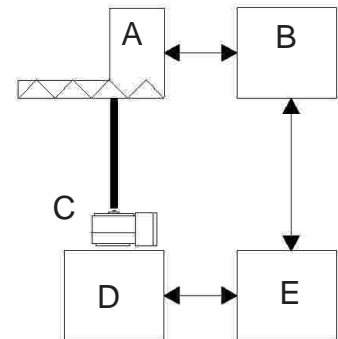

Brief Description

Application

CSL stands for Colortronic Smart Load Cell. The CSL is a force transducer which can be applied in a wide range of applications in the process control industry.

The weighing technology is based on a vibrating wire.

Features

- Single string vibrating wire transducer with built-in microprocessor
- Integrated electronic linearization control.
- Integrated electronic temperature compensation control
- Integrated digital filter to eliminate vibration
- Direct digital weight data acquisition
- Optimal repeatability and stability
- Extremely high resolution:
0.0001% (1: 1,000,000)
- Serial port RS485
- Addressable easy two-way communication
- No vibration protection required
- Rugged construction



Technical Information

- Accuracy: $\pm 0.03\%$ (300ppm)
- Internal resolution: 1,000,000 ppm (parts per million)
- Compensated temperature sensitivity:
Range max. 4 ppm/ °C 2.2 ppm/°F
Zero max 10 ppm/ °C 5.6 ppm/°F
- Measurement filter:
Series connection for programming of measurement filter
- Load cell capacities:
15, 30, 60, 150, 300, 600 kg
33, 66, 132, 330, 660, 1320 lb
- Operating temperature: -10 to +50 °C +14 to +122 °F
- Storage temperature: -30 to +70 °C -22 to +158 °F
- Maximum Shock Load:
calibrated 100 G, all directions
non calibrated 75 G, all directions
- Transmission distance: max 500 m max. 1,640 ft
- Interface:
RS485 Bus protocol Intel 8051
serial: Mode 3 format Bus Address 0-15 CSL
Baud rate 2.4 kB to 38.4 kB
Detailed information on request
- Measurement Intervals adjustable from 150 ms to 4.5 s
- Electrical connection 7 to 15 V DC max 125 mA
(25 °C/ 77°F)
- Power consumption 1 W / 10 V DC
- Cable length approx. 1.5 m approx. 4.9 ft
- Enclosure protection class IP65

Operating Principle

The Colortronic Smart Load Cell (CSL) uses the principle of measuring the variable resonant frequency of a vibrating wire subjected to an applied load - unknown and variable. Through mechanical means, the applied load is transmitted to the wire, causing a change in its resonant frequency. By monitoring and manipulating the resonant frequency through the on-board microprocessor, the value of the applied load is computed in engineering units. The resultant signal which is fully calibrated is transmitted via RS 485 serial communication to the controller. Data is transferred at baud rates from 2,400 to 38,400.

Because the resonance frequency is not constantly linear to wire tension, all the various force transducers are "linearized" and all data is stored in an EEPROM. The temperature compensation takes place with an integrated temperature sensor.

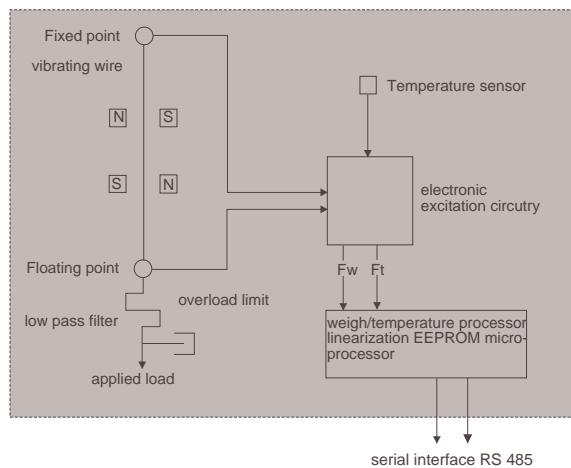

www.colortronic.com

Colortronic GmbH
Germany

☎ +49 61 75 7 92-0
☎ +49 61 75 7 92-1 79
✉ info@colortronic.de

Colortronic Inc.
USA

☎ +1 856 312 96 00
☎ +1 856 312 96 96
✉ ctusa@colortronic.com

Colortronic Systems Pte. Ltd
Singapore

☎ +65 77 77 665
☎ +65 77 88 671
✉ ctasia@colortronic.com

Colortronic U.K. Ltd.
Great Britain

☎ +44 12 46 260 222
☎ +44 12 46 455 420
✉ sales@colortronic.co.uk

Colortronic s.a.r.l.
France

☎ +33 03 88 59 18 10
☎ +33 03 88 59 18 11
✉ ctfrance@colortronic.com

Colortronic AG
Switzerland

☎ +41 62 889 25 25
☎ +41 62 889 25 26
✉ info@colortronic.ch