

Typical application of a dry air drying system.

A Drying System  
B Single Conveying System  
C Processing Machine

Components A and B are described below.

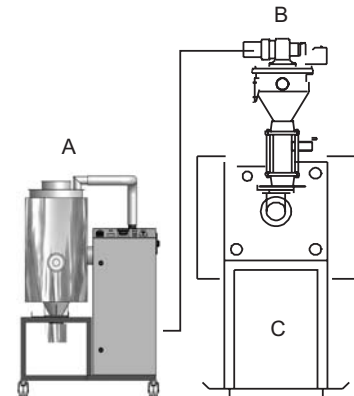

## Brief Description

### Application

Mobile drying system for the drying of thermoplastic granules and regrind, independent of climate or ambient air conditions, before processing to remove all remaining moisture from the granules both inside and out.

- Colortronic drying systems are designed for continuous, 24 hour operation
- Colortronic drying systems meet all CE requirements

### Rugged, modular construction

Colortronic dry air dryers operate on the principle of absorption. Under this principle, the air is not heated, rather the moisture is absorbed and removed from it inside the drying hopper. Through this technology plastic granules can be dried to extremely low residual moisture levels. Colortronic Dry-Flex S 40 Mobile dry air dryers have 2 drying cells which continuously maintain a dew point level of up to  $-60^{\circ}\text{C}$ . Because our air flow is constant, we maintain zero temperature change during the drying process.

Colortronic dry air dryers are virtually maintenance free. Only the air filters required routine cleaning or change out.



**Technical Information**

**Basic Version**

- **Dryer**
  - 2 drying cells for continuous operation
  - integrated hopper heating
  - Safety temperature limiter for all heaters
  - Maintenance free air valves
- **Drying hopper 30 liters**
  - made of stainless steel
  - hinged lid
- **Mobile frame**

**Optional Equipment**

- Drying hopper with 50 l capacity instead of 30 l
- Drying hopper with 75 l capacity instead of 30 l
- Dew point display
- Timer clock
- Single conveying system CSV 05 incl. 5 m PUR hose
- Suction box for drying hopper

**Performance**

- Max. 1 drying hopper
- Air drying capacity 40 m³/hr
- Operating voltage 230 V +/-10%, AC, 50/60 Hz
- Connected load 1.3 kw +max. 1.5 kw hopper heating
- Average dewpoint temperature of -50° C (- 76 °F)

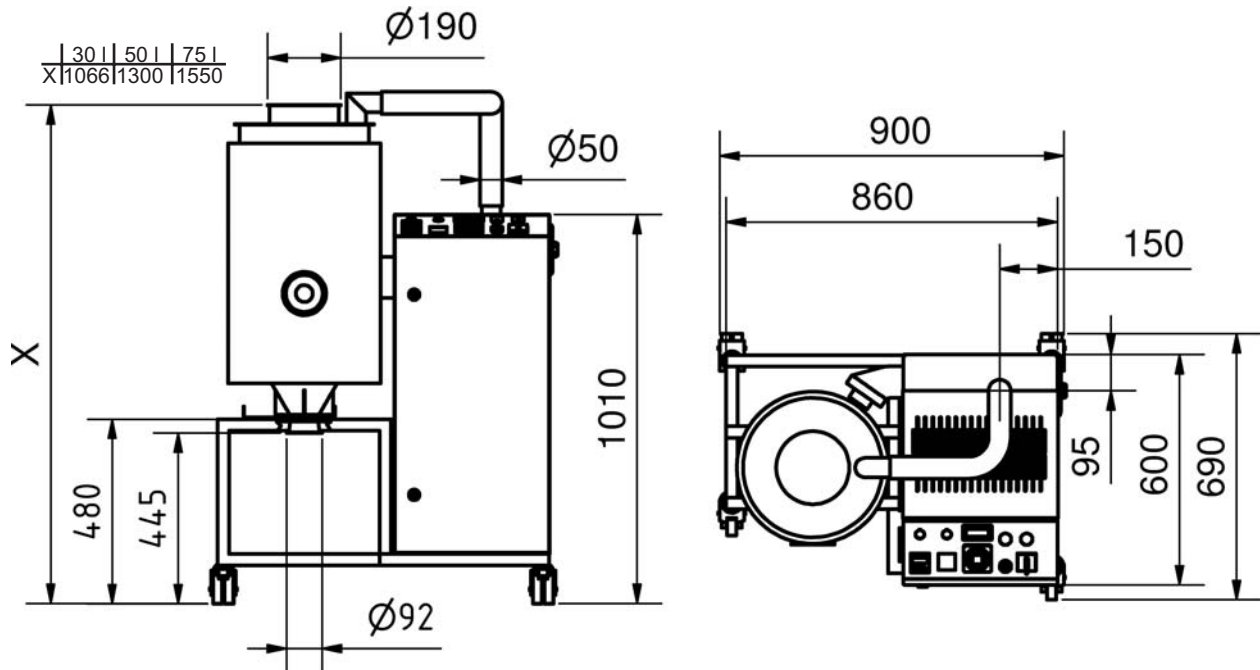

www.colortronic.com

**Colortronic GmbH**  
Germany  
☎ +49 6175 792-0  
☎ +49 6175 792-1 79  
✉ info@colortronic.de

**Colortronic AG**  
Switzerland  
☎ +41 62 889 25 25  
☎ +41 62 889 25 26  
✉ info@colortronic.ch

**Colortronic N.A. Inc.**  
USA  
☎ +1 810 720 73 00  
☎ +1 810 720 25 98  
✉ ctusa@colortronic.com

**Colortronic Systems Pte. Ltd**  
Singapore  
☎ +65 677 77 665  
☎ +65 677 88 671  
✉ ctasia@colortronic.com

**Colortronic s.a.r.l.**  
France  
☎ +33 03 88 59 18 10  
☎ +33 03 88 59 18 11  
✉ ctfrance@colortronic.com

**Colortronic srl**  
Italy  
☎ +39 0 131 87 29 33  
☎ +39 0 131 87 29 41  
✉ info@colortronic.it

**Colortronic U.K. Ltd.**  
United Kingdom  
☎ +44 12 46 260 222  
☎ +44 12 46 455 420  
✉ sales@colortronic.co.uk

**Colortronic Kft. South East Europe**  
Hungary  
☎ +36 263 610 51  
☎ +36 263 610 51  
✉ kft@colortronic.info