

Typical application of a Gravimetric Control System

- A Dosing control system
- B Gravimetric dosing unit
- C Printer
- D Host

Component B is described below.

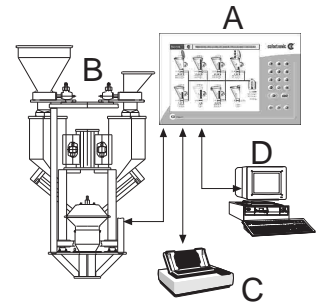

Brief Description

Graviblend M/L is a continuous loss-in-weight gravimetric dosing and blending system for free flowing plastic pellets.

Each Graviblend M/L can have one to eight precision screw feeders per line.

Graviblend M/L is designed for throughput from 0.25 kg/h (0.55 lb/hr) to 2,000 kg/h (4,400 lb/hr). These throughputs are achieved only in continuous extrusion applications.

The dosing of the components is done continuously. The material flow for each component is constantly monitored and regulated.

- Graviblend is manufactured in accordance with "CE" specifications.



Technical Information

Basic Version

- Max. eight dosing/feeder stations per blending unit
- Minimum throughput
Graviblend M: 0.25 kg/h (0.55 lb/hr)
Graviblend L: 0.5 kg/h (1.1 lb/hr)
- Maximum throughput
Graviblend M: 500 kg/h (1,100 lb/hr)
Graviblend L: 2,000 kg/h (4,400 lb/hr)
- Maximum material temperature 65°C (150°F)
- Weight with one dosing/feeding station appr.
Graviblend M: 40 kg (88 lb)
Graviblend L: 60 kg (132 lb)
- Weight of one modular dosing/feeding station appr.
Graviblend M: 12 kg (27 lb)
Graviblend L: 28 kg (62 lb)
- Operating voltage 230 V ±10%, AC, N, PE, 50/60 Hz
- Cumulative Dosing Accuracy up to ±0.1%
- Variable speed DC drive motors
- Vibrating wire load cells with a resolution of 1:1,000,000 per dosing/feeding station

Optional Equipment

- Vacuum conveying units/system for feeder refill
- Vibration damping
- High temperature (180°C/356°F) option available
- Disc dosing unit for very low rates

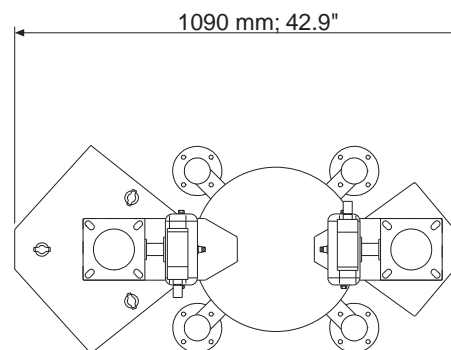
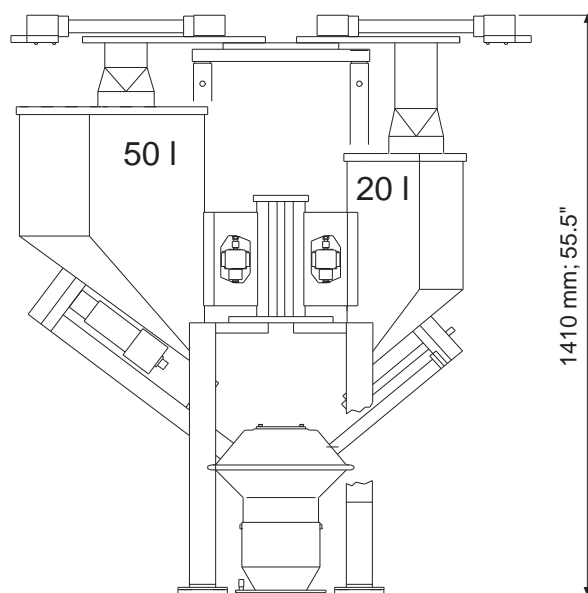

www.colortronic.com

Colortronic GmbH
Germany

☎ +49 61 75 7 92-0
☎ +49 61 75 7 92-1 79
✉ info@colortronic.de

Colortronic Inc.
USA

☎ +1 856 312 96 00
☎ +1 856 312 96 96
✉ ctusa@colortronic.com

Colortronic Systems Pte. Ltd
Singapore

☎ +65 77 77 665
☎ +65 77 88 671
✉ ctasia@colortronic.com

Colortronic U.K. Ltd.
Great Britain

☎ +44 12 46 260 222
☎ +44 12 46 455 420
✉ sales@colortronic.co.uk

Colortronic s.a.r.l.
France

☎ +33 03 88 59 18 10
☎ +33 03 88 59 18 11
✉ ctfrance@colortronic.com

Colortronic AG
Switzerland

☎ +41 62 889 25 25
☎ +41 62 889 25 26
✉ info@colortronic.ch