

Typical application of a Gravimetric Control System

- A Dosing control system
- B Gravimetric dosing unit
- C Printer
- D Host

Component B is described below.

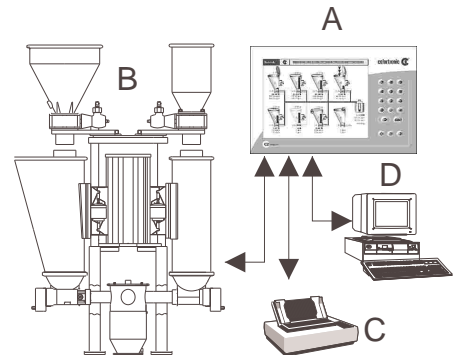

Brief Description

Graviblend Plus is a continuous loss-in-weight gravimetric dosing and blending system for free flowing plastic pellets.

Each Graviblend Plus can have one to eight precision screw feeders per line.

Graviblend Plus is designed for throughput from 0.25 kg/h (0.55 lb/hr) to 7,500 kg/h (16,500 lb/hr). These throughputs are achieved only in continuous extrusion applications.

The dosing of the components is done continuously. The material flow for each component is constantly monitored and regulated.

- Graviblend is manufactured in accordance with "CE" specifications.



Technical Information

Basic Version

- Basic Version
- Max. eight dosing/feeder stations per blending unit
- Minimum throughput 0.25 kg/h (0.55 lbs/hr)
- Maximum throughput 7,500 kg/h (16,500 lbs/hr)
- Maximum material temperature 100°C (212°F)
- Weight with one dosing/feeding station 50 kg (110 lbs)
- Weight of one modular dosing/feeding station 15-40 kg (33-88 lbs)
- Volume of one modular feeder/dosing container 20-90 liters (0.7 cu. FT - 3.18 cu. FT)
- Operating voltage 230 V ±10%, AC, N, PE, 50/60 Hz
- Cumulative Dosing Accuracy up to ±0.1%
- Variable speed DC drive motors
- Standard dust-tight construction
- Vibrating wire load cells with a resolution of 1:1,000,000 per dosing/feeding station

Optional Equipment

- Twin screw feeder dosing station with built-in agitator
- Processing of liquid components
- Integrated re-fill system
- Vacuum conveying units/system for feeder refill
- Vibration damping
- High temperature (180°C/356°F) option available

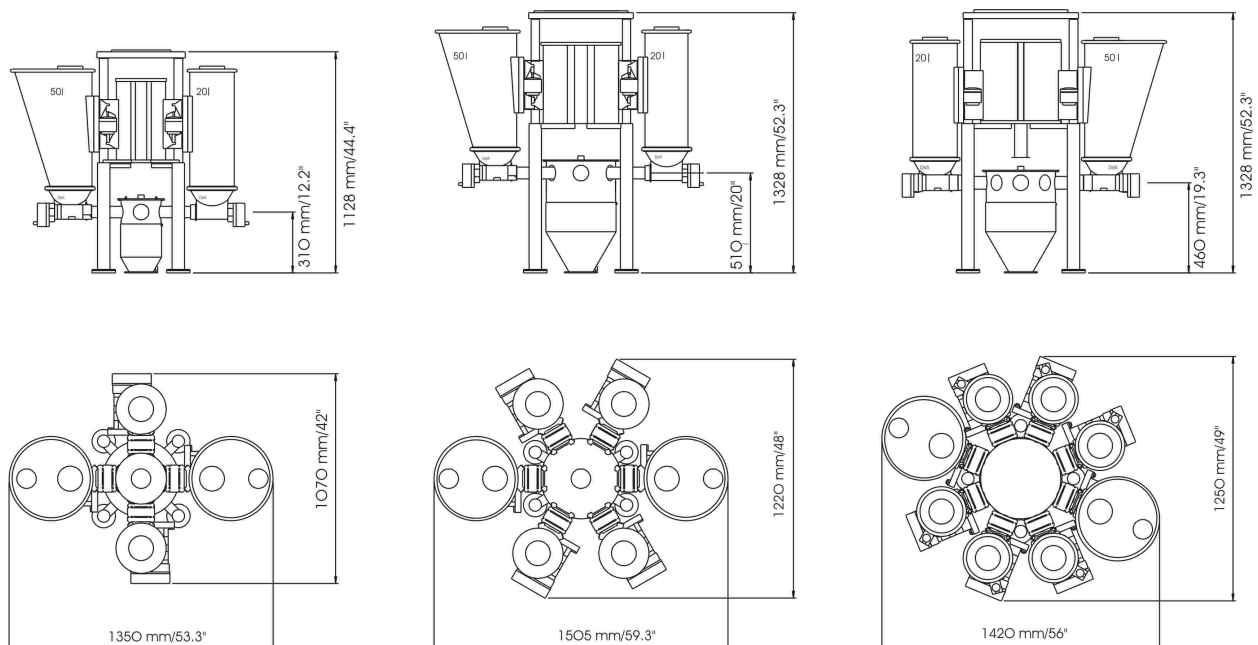

www.colortronic.com

Colortronic GmbH
Germany

☎ +49 61 75 7 92-0
☎ +49 61 75 7 92-1 79
✉ info@colortronic.de

Colortronic Inc.
USA

☎ +1 856 312 96 00
☎ +1 856 312 96 96
✉ ctusa@colortronic.com

Colortronic Systems Pte. Ltd
Singapore

☎ +65 77 77 665
☎ +65 77 88 671
✉ ctasia@colortronic.com

Colortronic U.K. Ltd.
Great Britain

☎ +44 12 46 260 222
☎ +44 12 46 455 420
✉ sales@colortronic.co.uk

Colortronic s.a.r.l.
France

☎ +33 03 88 59 18 10
☎ +33 03 88 59 18 11
✉ ctfrance@colortronic.com

Colortronic AG
Switzerland

☎ +41 62 889 25 25
☎ +41 62 889 25 26
✉ info@colortronic.ch