

Standard suction units with fines separator series HS



The fines separator HS series is a new accessory for granulators and size reduction lines offered by HERBOLD and is suitable not only for new systems but can also be installed as an improvement to existing systems. The units are simple constructions and low-priced. They are of particular interest where beside-the-press granulators are in use, e.g. in injection moulding or blow moulding production lines.

The fines separator puts an end to the inconveniences of conventional dust separators:

- The unit not only removes dust from the granulate but also prevents dust and fluffs (a particular problem when dealing with HD-PE blow or injection waste) from soiling the plant rooms. No residual dust is discharged with the exhaust air.
- The cleaning of the unit can be carried out easily and quickly. There are no rotating parts in the separator that could lead to break-downs.
- The unit implements the force of gravity, i.e. the entry and exit of the unit are in the same axis. This simplifies fitting the unit as a later addition to existing systems.
- The degree of separation can variably be adjusted using the regulator flap.

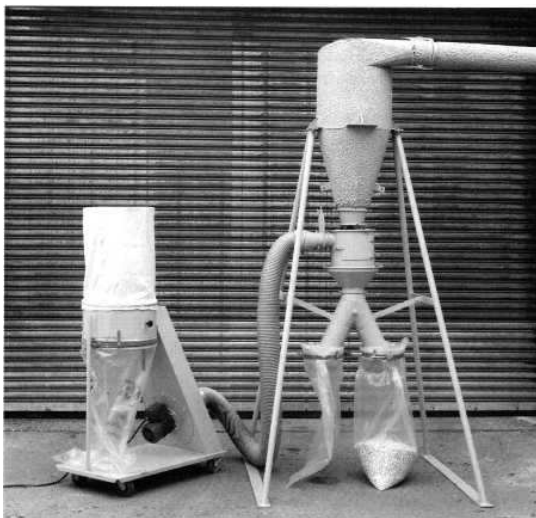

cyclone separator with fines separator HS 300 (sack filling model)

The fines separator is of compact design and can be fitted under any granulate discharge opening. The picture shows the fines separator underneath the granulate cyclone. It has a height of approx. 19.75" (500 mm) so that under unfavourable conditions only the cyclone separator would have to be elevated. In cases of limited headroom HERBOLD can offer a special compact cyclone with separator to suit the given structural limitations.

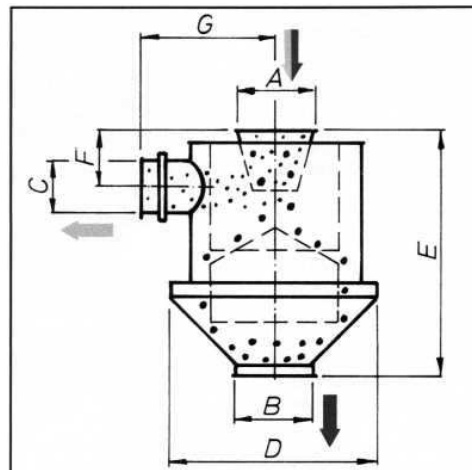

schematic drawing of fines separator HS

Type	Ø A	Ø B	Ø C	Ø D	E	F	G	Throughput
HS 300	6" 150 mm	6" 150 mm	4" 100 mm	16" 390 mm	18.5" 470 mm	4" 100 mm	10" 250 mm	up to 1,5 t/h up to 3000 lbs/h
HS 500	6" 150 mm	6" 150 mm	6" 150 mm	1' 10" 580 mm	4' 3" 1300 mm	1.8" 45 mm	1' 4" 400 mm	up to 4,0 t/h up to 8000 lbs/h

A positive secondary effect of fitting a HERBOLD fines separator:

Since this is a suction unit the material is not under pressure when leaving the separator. It is possible to fill the granulate into open containers or boxes or to feed it to a follow-up metal

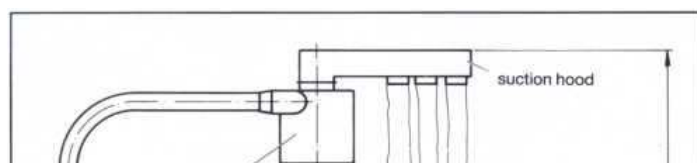

separator without the use of a bucket wheel sluice or other air tight equipment.

We also supply air separators of the TWR series for particularly difficult problems (e.g. PS/Alu separation).

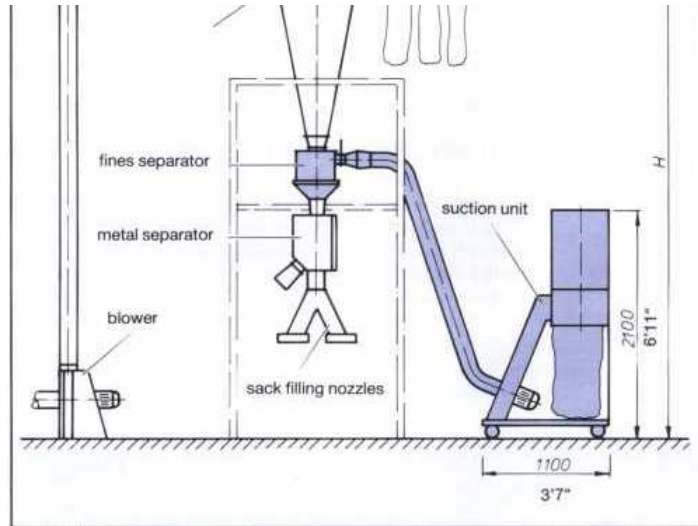

Construction height* H (ft' in") H (mm)*	Container filling (Outlet height 4' 3") Sack filling (Outlet height 4' 3")	Suction unit type 8 (283 ft ³ /min) Blower 2 HP	Suction unit type 18 (263 ft ³ /min) Blower 2 HP	Suction unit type 30 (1058 ft ³ /min) Blower 5.5 HP	Suction unit type 45 and 55 1587 ft ³ /m-1940 ft ³ /m Blower 10 HP 15 HP
		Standard model: Cyclone separator with suction hood only	8' 5" 2560	11' 6" 3500	4500 14' 9" 14' 9" 4500
Standard model: + fines separator	9' 11" 3030	11' 6" 3500	4500 14' 9" 14' 9" 4500	5450 17' 11" 14' 9" 4500	5450 17' 11" 18' 9" 5700
Standard model: + metal separator	9' 11" 3030	11' 6" 3500	4500 14' 9" 14' 9" 4500	5450 17' 11" 14' 9" 4500	5450 17' 11" 14' 9" 4500
Standard model: + fines separator + metal separator	11' 6" 3500	13' 5" 4100	5100 16' 9" 16' 5" 5000	5920 19' 5" 16' 5" 5000	6750 22' 2" 18' 9" 5700

* These units can be supplied as specially adapted models in two stages with material transfer equipment, in cases where the available room height is inadequate.



Our product range

- Granulators
- Pulverizing Systems
- Shredders
- Hammer Mills
- HOG Shredders
- Guillotines
- Washing Systems
- Plastcompactors

Herbold Meckesheim GmbH

Industriestr. 33
D-74909 Meckesheim
Postfach 1218
D-74908 Meckesheim
Tel.: + 49 (0) 6226/932-0
Fax: + 49 (0) 6226/932-495
E-Mail: Herbold@Herbold.com
Internet: www.Herbold.com

Our US-Subsidiary:

Herbold Meckesheim USA
Resource Recycling Systems Inc.
333 George Washington Highway,
USA-Smithfield,
Rhode Island 02917
Phone: + 1 401-232-3354
Fax: + 1 401-232-5425
info@HerboldUSA.net
www.HerboldUSA.net