

Multiple-Knife Granulators for Fine Grinding SMF Series

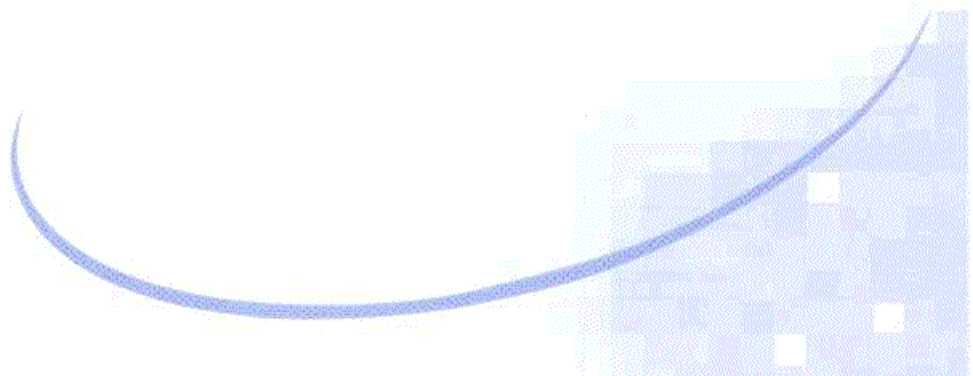

Fine Granulator SMF Series

- High cutting sequence: up to 200,000 cuts per minute
- Open rotor design
- Pneumatic material discharge
- Guaranteed high throughput
- Sturdy, compact design



Advantageous Cutting Sequence

for a High Specific Capacity

HERBOLD Fine Granulators of the SMF 500/1000 series are fast running units with a high cutting sequence for grinding all types of material that can be cut.

The following models are available:

- Machine with gravitational feed for free flowing material that can be metered, optional:
- Machine with nip roll feed device for continuous material and rolls.
- Machine with a reduced cutting sequence for difficult applications.



Machine with feed device for continuous material and rolls

Typical materials

- Cellulose pulverization
- Plastic chips, e.g. from the production of pipes and profiles or the reduction of semifinished products
- Plastic fibers for the production of fillers and asbestos substitutes
- Foam for the production of special composite foams and for refeed to the solvent process
- Fine grinding of rubber
- Film processing without regranulating to improve the free-flowing qualities and increase the bulk density or storability

Mode of operation

The material to be reduced is fed to the grinding chamber by gravitation or via a nip roll feed device. Cutting is carried out very quickly between the rotor and stator knives operating in a narrow gap against each other. A screen fitted beneath the grinding chamber allows the reduced material to pass when the required grain size has been reached..

The rotor is mounted in precision bearings which are sealed off from the grinding chamber. Material discharge is carried out pneumatically, the suction unit also having the function of cooling the grinding chamber and the process material.

An essential feature of the HERBOLD Fine Granulator SMF 500/1000 is the open rotor design. This prevents an air barrier effect and allows a high throughput of cooling air. The results being the production of a top quality powder with a high throughput.

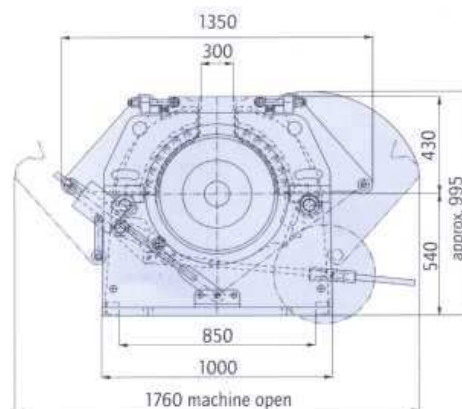
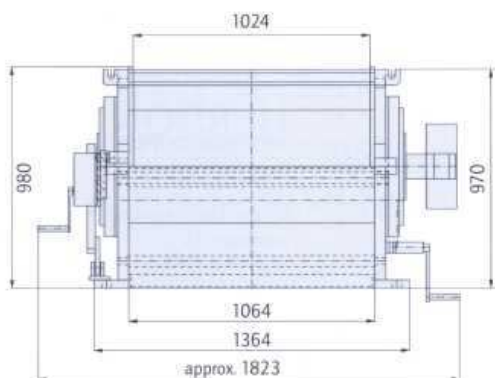



Complete line for the pulverization of cellulose with explosion proof protection

Advantages:

- Closely defined particle size distribution with few fines
- Minimal temperature increases; housing and end shields available with water cooling
- Finely reduced material has smooth cut surfaces with good free-flowing qualities
- High specific throughput and efficiency
- Sturdy, compact design
- Long service life of the cutters due to the use of special steels

Anwendungsbereiche

- All types of material which have to be reduced finely by cutting, e.g. material that is sensitive to temperature changes and material for which good free-flowing characteristics, high bulk density and few fines are demanded.
- The HERBOLD Fine Granulator SMF 500/1000 (16 rows of rotor knives x 12 rows of stator knives results in almost 200 cuts per revolution) is causing an extremely high specific capacity. The heat generated during the grinding process can be discharged by a water cooling if heat sensitive materials are to be processed. The housing in the stator blade area is then jacketed and provided for water cooling.
- The HERBOLD Fine Granulators of the SMF 500/1000 series have been manufactured using both welded steel and ductile (spherulitic graphite) iron components. This rugged design, when compared to similar gray cast iron machines, is much more suited to withstand heavy duty applications - especially if upset peak loads occur.
- To prevent overheating, the unit can be water cooled. The standard arrangement is to add this feature only to the end plates; however, the housing can be included as well. Water cooling can improve both the quality of the product and the throughput of the machine.

Resistance Technique for the Pulverization of All Materials that Can Be Cut

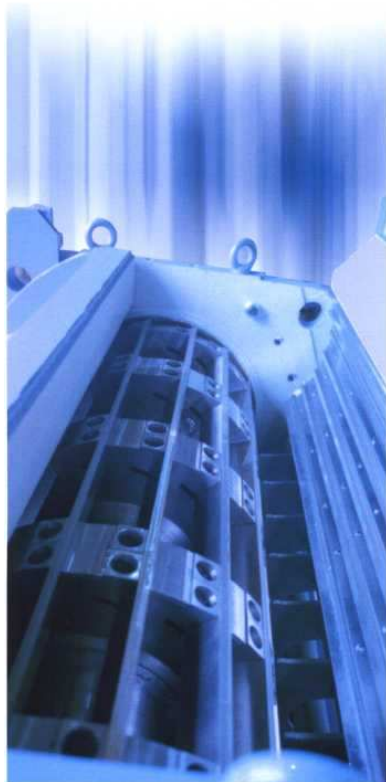

Accessories:

- Metal separators for the removal of foreign matters from the feed material
- Noise protection devices
- Pressure shock resistant measures
- Suction units and filtration devices
- Preliminary coarse reduction units and the supply of custom-made, turn key systems

Test center and trials:

A generously equipped test centre is available for practice-oriented trials.

HERBOLD size reduction technique

A large range of products for the size reduction and the recycling of a variety of waste materials and other products

Technical Data

Rotor diameter	500 mm (19.5")
Working width	1000 mm (39")
Cutting system	Double cross cut
Rotor knives no.	16 rows of single or multi-sectional knives (optional: 5 or 9 rows)
Stator knives no.	12 (optional: 6 or 7)
Drive power	45 - 90 kW (60 - 125 HP)
Throughput	50 - 2000 kg/h (110 - 4400 lbs/h) (dependent on fineness and material)
Feed opening	300 x 1000 mm
Weight, basic unit	approx. 6000 kg (13200 lbs)

Specifications are not binding and subject to change without notice -
Edition: 09/2004



Our product range

- Granulators
- Pulverizing Systems
- Shredders
- Hammer Mills
- HOG Shredders
- Guillotines
- Washing Systems
- Plastcompactors

Herbold Meckesheim GmbH

**Industriestrasse 33
D-74909 Meckesheim**

**Postfach 1218
D-74908 Meckesheim**

**Tel.: +49 (0) 62 26 / 932-0
Fax: +49 (0) 62 26 /
932-495**

**E-Mail:
Herbold@Herbold.com**

**Internet:
<http://www.herbold.com>**

Our US-subsiidiary:

**Herbold Meckesheim USA
Resource Recycling Systems Inc.
333 George Washington Highway,
Smithfield Rhode Island 02917**

**Phone: +1 401-232-3354
or +1 888-612-7774**

**Fax: +1 401 232 5425
E-Mail: Info@HerboldUSA.net
Internet: www.HerboldUSA.net**