

Typical application of direct regrind feedback.

- A Conveying unit
- B Injection molding machine
- C Dosing and blending unit
- D Granulator
- E Two-component proportioning valve

Component D is described below.

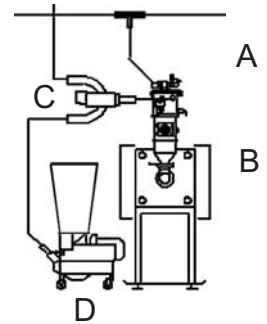

Brief Description

Portable, slow running granulator with feed chute, motor overload protection and visual alarm signal. Easy to maintain and quick to clean. Hinged construction allows easy accessibility to the cutting chamber.

Handles all sprues and rejects from injection molding machines.

- Colortronic granulators are easy to maintain and designed for a 7 day, 24 hour operation.
- Colortronic granulators meet the european "CE" requirements.



Technical Data

Basic Version

- Maintenance free drive
- Staggered horizontal cutting rotor with 6 HSS steel rotor blades
- 2 HSS steel stator blades
- Suction box with integrated suction probe
Ø 40 mm / 1.5 in.
- Hardened perforated screen with various holes sizes available
Ø 3, 4, 5, 6, 8 mm / .12, .16, .20, .24, .31 in.
- Feed chute

Optional Equipment

- Overfill protection
- Special feed chute designs
- Steel coil feed
- Vibration feed
- Special voltages
- Blade setting tool
- Suction probe 50 mm

Performance

- Maximum material size 100 x 80 mm
- Maximum throughput appr. 15 kg/hr
- Rotor speed 96 RPM
- Cutting size 100 mm
- Power consumption 1,5 kW
- Voltages multiple voltage motor
400 V ±10 %, 3 AC, PE, 50 Hz
460 V ±10 %, 3 AC, PE, 60 Hz
- Protection class IP 54
- Color
Motor blue, RAL 5011
Chassis blue, RAL 5017
Housing white, RAL 9016
- Weight appr. 130 kgs

Drawing

	180/120	180/180	180/300	180/430
A (mm)	420	420	420	420
B (mm)	850	910	1030	1160
C (mm)	450	450	450	450
D (mm)	600	600	600	900

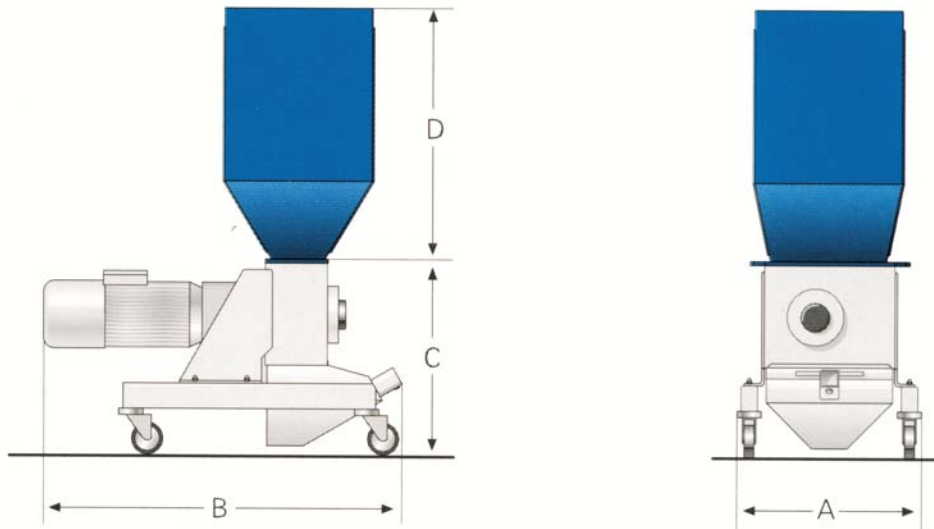

www.colortronic.com

Colortronic GmbH
Germany

☎ +49 6175 792-0
☎ +49 6175 792-1 79
✉ info@colortronic.de

Colortronic AG
Switzerland

☎ +41 62 889 25 25
☎ +41 62 889 25 26
✉ info@colortronic.ch

Colortronic N.A. Inc.
USA

☎ +1 810 720 73 00
☎ +1 810 720 25 98
✉ ctusa@colortronic.com

Colortronic Systems Pte. Ltd
Singapore

☎ +65 677 77 665
☎ +65 677 88 671
✉ ctasia@colortronic.com

Colortronic s.a.r.l.
France

☎ +33 03 88 59 18 10
☎ +33 03 88 59 18 11
✉ ctfrance@colortronic.com

Colortronic srl
Italy

☎ +39 0 131 87 29 33
☎ +39 0 131 87 29 41
✉ info@colortronic.it

Colortronic U.K. Ltd.
United Kingdom

☎ +44 12 46 260 222
☎ +44 12 46 455 420
✉ sales@colortronic.co.uk

Colortronic Kft. South East Europe
Hungary

☎ +36 263 610 51
☎ +36 263 610 51
✉ kft@colortronic.info