

Typical layout of a drying system.

- A Dry air dryer
- B Drying hopper with auxiliary heater

Component B is described below.

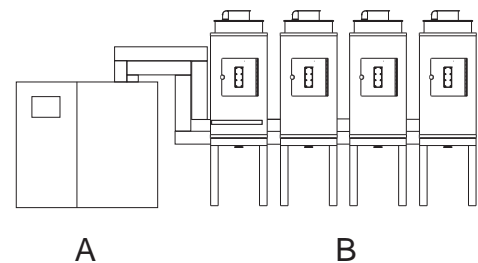

## Brief Description

### Application

Drying of thermoplastic granules and regrind, as part of a drying system.

- Colortronic drying hoppers are designed for continuous 24-hour operation.
- Colortronic drying hoppers meet the European "CE" requirements

### Rugged, modular construction

Colortronic drying hoppers are constructed of stainless steel or non-corrosive aluminum. Material and air flow have been carefully engineered for optimum drying results at high energy efficiency.

The drying hoppers are equipped with drying heaters which are controlled and monitored by the central dryer. The hopper is insulated into the discharge cone, preventing heat loss while serving as effective protection against accidental contact.



Technical Information

	TT25	TT60	TT100	TT200	TT400	TT800	TT1200	TT1600	TT2400	TT3200	TT4800	TT6400
sight glass	■											
clean-out opening	■											
clean-out opening with sight glass		■	■	■	■	■	■	■	■	■	■	■
stainless steel hopper	■	■	■	■	■	■	■	■	□	□	□	□
aluminium hopper									■	■	■	■
capacity	25 l	60 l	100 l	200 l	400 l	800 l	1200 l	1600 l	2400 l	3200 l	4800 l	6400 l
hopper heating*	400 V AC ±10 %, N, PE 1,5 kW, 3 kW, 6 kW, 9 kW, 18 kW, 27 kW, 36 kW, 48 kW, 63 kW											
<b>Dimensions**</b>												
A	190	253	253	253	253	253	430	430	430	430	430	430
B	1420	1590	1830	2060	2450	2515	2900	3580	4010	4430	5090	4180
C	92	92	92	92	92	92						
D	395	500	500	600	715	930	1070	1070	1260	1380	1535	2000
E	450	900	900	900	900	940	1050	1050				
F	80	80	80	80	80	80	150	150	150	163	163	163
G	92	92	92	92	92	92	163	163	163	163	163	163
(DIN 2642) C							NW100	NW100	NW100	NW150	NW150	NW150
■ base model, □ option												
*Configuration depends on application, **Dimension in mm												

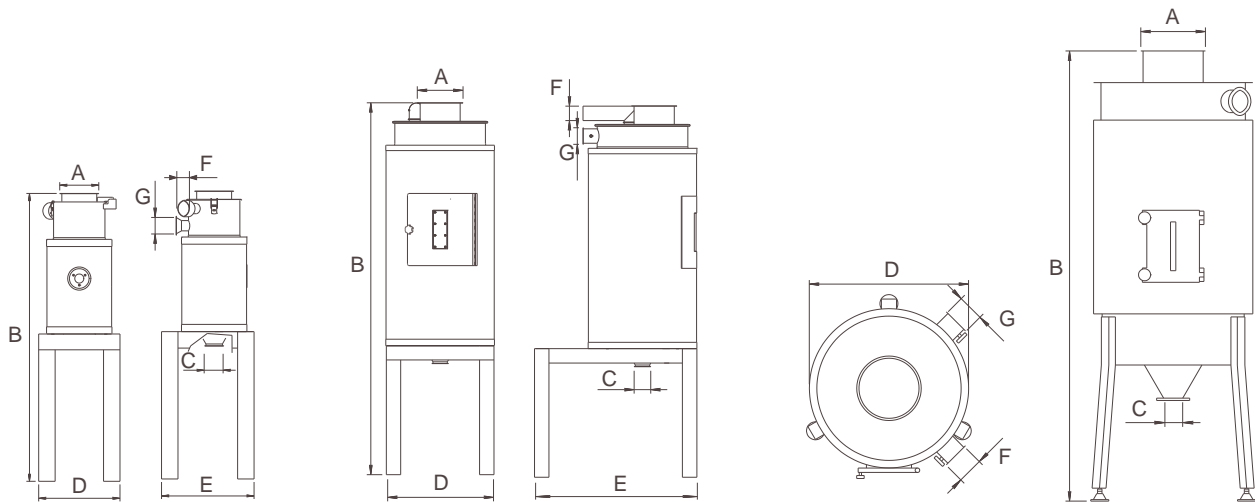

www.colortronic.com

Colortronic GmbH  
Germany

☎ +49 61 75 7 92-0  
☎ +49 61 75 7 92-1 79  
✉ info@colortronic.de

Colortronic Inc.  
USA

☎ +1 856 312 96 00  
☎ +1 856 312 96 96  
✉ ctusa@colortronic.com

Colortronic Systems Pte. Ltd  
Singapore

☎ +65 77 77 665  
☎ +65 77 88 671  
✉ ctasia@colortronic.com

Colortronic U.K. Ltd.  
Great Britain

☎ +44 12 46 260 222  
☎ +44 12 46 455 420  
✉ sales@colortronic.co.uk

Colortronic s.a.r.l.  
France

☎ +33 03 88 59 18 10  
☎ +33 03 88 59 18 11  
✉ ctfrance@colortronic.com

Colortronic AG  
Switzerland

☎ +41 62 889 25 25  
☎ +41 62 889 25 26  
✉ info@colortronic.ch